

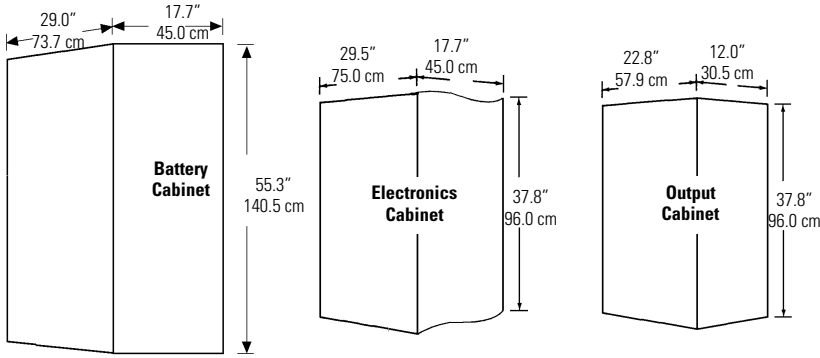

L1PH Series Uninterruptible Power Supplies **L1PH**

Operates incandescent, magnetic and electronic ballast fluorescent, high power factor compact fluorescent, and high intensity discharge (HID) lamp types.



Unit	6.0 kVA
Battery Cabinet	1,330 lbs. (603 kg)
Electronics Cabinet	209 lbs. (95 kg)
Output Cabinet	155 lbs. (70 kg)
Total Unit	1,694 lbs. (768 kg)

How to Specify:

L1PH		I	6.0	S						
SERIES	INPUT VOLTAGE	SYSTEM TYPE	BASE SIZE	BATTERY TYPE	OUTPUT VOLTAGE	OUTPUT CKT BRKRS¹	# ON 2ND VOLTAGE	NORMALLY OFF LOAD	# OF NOL	NOL VOLTAGE
L1PH = Single Phase Uninterruptible Power Supplies	1 = 120 V 2 = 208 V 3 = 240 V 4 = 277 V Z = Special Voltage (Consult Factory)	I = ETL Listed to UL 924 for Emergency Lighting Applications	6.0 = 6.0 kVa	S = Sealed Lead Calcium	1 = 120 V 2 = 208 V 3 = 240 V 4 = 277 V 5 = 120/208 V 6 = 120/240 V 7 = 120/277 V Z = Special Voltage (Consult Factory)	Y = Hardwire A = 1 OCB B = 2 OCB C = 3 OCB D = 4 OCB E = 5 OCB F = 6 OCB G = 7 OCB H = 8 OCB J = 9 OCB K = 10 OCB L = 11 OCB M = 12 OCB N = OCBA1 P = OCBA2 R = OCBA3 S = OCBA4 T = OCBA5 U = OCBA6 V = OCBA7 W = OCBA8 X = OCBA9	0 1 2 3 4 5 6 7 8 9 10 11	A = No B = Yes C = Yes w/ Time Delay Timer	0 = No NOL Y = Hardwire Terminal 1 = 1 2 = 2 3 = 3 4 = 4 5 = 5 6 = 6 7 = 7 8 = 8 9 = 9 10 = 10 11 = 11 12 = 12	X = None A = 1st B = 2nd

NOTE: Input circuit breaker not available. Input switch is standard.

Overall Characteristics

- 86% throughput efficiency
- Operating temperature range 32°F (0°C) to 104°F (40°C)
- Internal maintenance by-pass is standard
- Main load disconnect switch standard
- Double conversion, no interruption
- Standard backup time of 90 minutes, other run times optional
- Output circuit breakers and normally-off loads optional

Housing

- Free standing, NEMA 1 enclosure
- Acid resistant powder coat finish
- Multiple conduit entries

Metering/Controls

Standard

- Alpha-numeric front panel display with 14 metered measurements and 53 messages/alarms
- Normal, caution and alarm indicating LEDs
- Audible failure alarms with silence switch
- Dry contact for remote failure alarm
- "D" type 9-pin computer interface connector (see pin config. on back)
- Programmable battery monitor with alarm

Optional

- Diagnostics software for remote computer (PC) monitoring and control
- Stand-alone remote display mimics all measurements, indications and alarms shown on the front panel display
- Additional RS-232 input/output port for remote monitoring and system control

Electrical

- Sine Wave Output
- Completely solid-state Pulse Width Modulation (PWM) inverter
- 16-bit microprocessor control
- Input power factor correction maintains power factor at 0.99
- Transient response ≤ 5%; Recovery time, 10 mS (100% load step)
- 3:1 crest factor capability
- Inverter output distortion ≤ 2.5% THD (at unity power factor)
- Output voltage regulation ±6% of nominal at full load
- Frequency within ±0.05% of nominal
- Inverter efficiency ≥ 84%

(Continued on page 2)

Job Information	Type:
Job Name:	
Cat. No.:	
Lamp(s):	
Notes:	

Lightolier a Genlyte Thomas Company www.lightolier.com
 631 Airport Road, Fall River, MA 02720 • (508) 679-8131 • Fax (508) 674-4710
 We reserve the right to change details of design, materials and finish.
 © 2004 Genlyte Thomas Group LLC (Lightolier Division) • D0504

LIGHTOLIER



Electrical (continued from page 1)

- Load power factor capability is 0.5 leading to 0.5 lagging
- Automatic, battery protecting low voltage disconnect (LVD)
- Advanced battery diagnostics and management system
- Temperature compensated battery charger
- 24 hour recharge time
- High frequency, very low ripple current charger
- Input and output disconnect switch
- Battery disconnect switch

Battery

Maintenance free, sealed lead calcium battery has an estimated service life of 10 years, and an operating temperature range of 65°F (19°C) to 85°F (30°C).

Options

- 0 = None
- 1 = PC Format Diagnostics Software
- 4 = Remote Display + "5"
- 5 = Additional RS-232

System Input/Output Ratings

SYSTEM RATING	INPUT VOLTAGE	INPUT AMPS ¹	AVAILABLE OUTPUT VOLTAGES/ MAX. LOAD AMPS ²				OCB POLE SPACES AVAILABLE
			120 V	208 V	240 V	277 V	
6,000 VA	—/277 208/240	—/27.6 35.8/30.6	50.0 A	—	—	21.6 A	12 12
			50.0 A	28.8 A	25.0 A	—	

NOTES:
 1) Continuous Duty
 2) Total Load Not to Exceed System Rating

Warranty

Standard Warranty

Lightolier will provide parts and on-site labor for the first 90 days following shipment of product, and parts only for an additional 270 days.

Extended Warranty

(Available with purchase of Factory Start-Up Service) Lightolier will provide parts and on-site labor for the first 12 months following start-up of the product, and parts only for an additional 12 months.

System One-Line Diagram

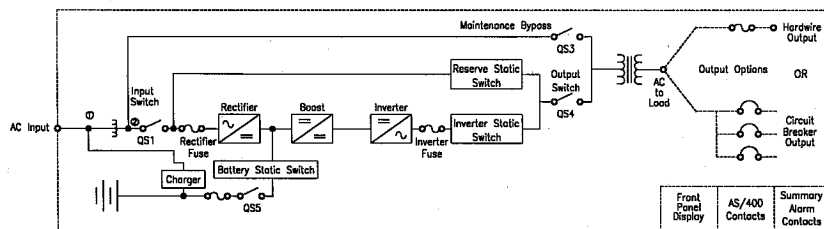

Computer Interface Pin Configuration

(AS/400™)

Pin	Description	Function
8	Normal	System Functioning Normally
6	Load On Reserve	Double Conversion Inverter Not Operating
9	Power Failure	Load Supplied by Battery
7	End of Discharge Period	Unit Will Soon Stop Operating
5	Common	Common Connection to Above 4 Signals

LIGHTOLIER



Listed to UL 924

Job Information Type:

Lightolier a Genlyte Thomas Company www.lightolier.com
 631 Airport Road, Fall River, MA 02720 • (508) 679-8131 • Fax (508) 674-4710
 We reserve the right to change details of design, materials and finish.
 © 2004 Genlyte Thomas Group LLC (Lightolier Division) • D0504