

# Architectural Decorative Vetro Downlight **DM14**

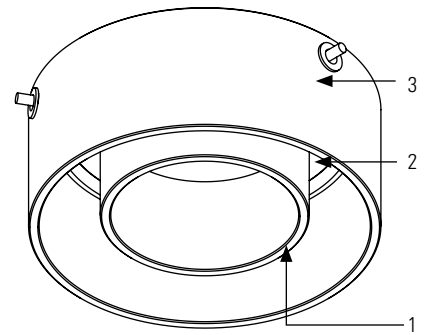
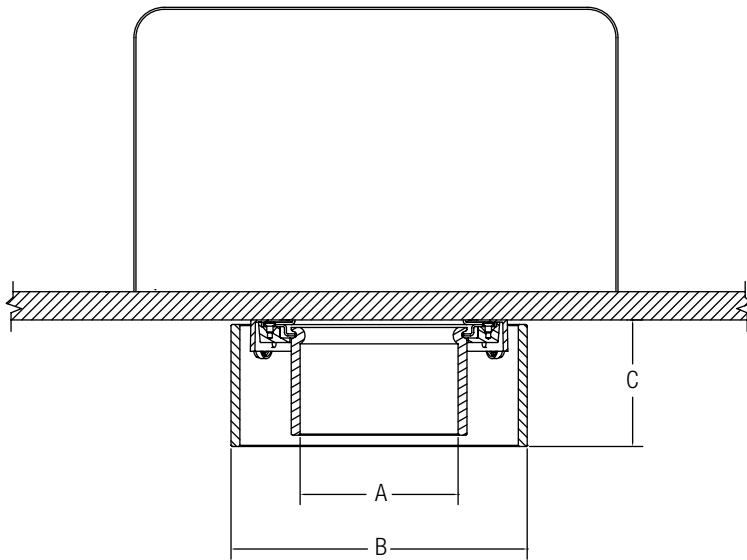

Complete fixture consists of Decorative Element/Trim-Kit + Frame-In Kit. Each sold separately.  
**2 Piece Ordering System, Example: D3MR14+ C3LV**

Decorative Element/Trim Kit Catalog No.		Frame-In Kit	Lamping	Dimensions		
				A	B	C
<b>3" Evolution</b>	<b>D3MR14</b>	C3LV, C3AICLV, C3ALV, C3LVE1, C3LVE2, C3ALVE1, C3AICLVE1, C3ALVE2	50W MR16	2 3/4"	5 1/4"	2 1/4"
<b>4" Evolution</b>	<b>D4MR14</b>	C4LV; C4ALV; C4AICLV	50W MR16	4"	6 3/4"	2 1/2"

## Features

- Decorative Element:** Solid high temp, UV resistant composite with open aperture; frosted interior diameter, polished exterior and machined facet along bottom edge.
- Die Cast Construction Ring:** Exterior edge of construction ring is visible, satin aluminum finish matches diameter of decorative element for a flangeless appearance.
- Integral Reflector:** 16 ga. aluminum, 50° visual cutoff to lamp and lamp image. Decorative Element is mechanically attached to reflector via die cast ring. Reflector is specular clear for best performance and aesthetics.
- Cover Glass:** 3" Evolution contains high temperature soft focus lens. 4" Evolution contains high temperature perimeter frost.
- Trim Kit:** For 3" and 4" Evolution, trim kit, reflector and decorative element ship complete.
- Frame-In Kit:** Specified separately. See Trim Kit Specification Sheet for details.

## Mechanical

Decorative element is mechanically secured to the die cast construction ring and the integral reflector from the factory.

## Labels

U.L. (Damp Location)

## Job Information

Type:

Job Name:

Cat. No.:

Lamp(s):

Notes: