

Decorative Vetro, 4" & 6" Metal Halide

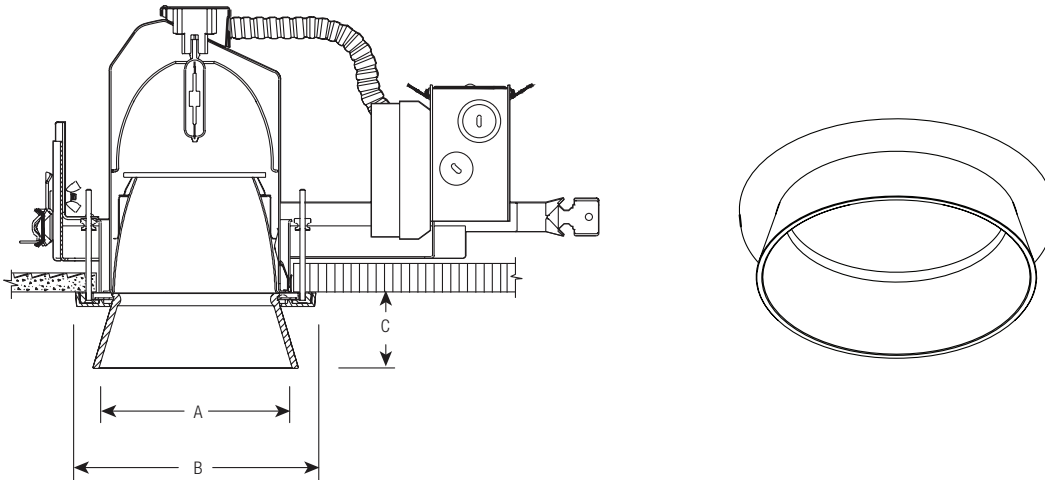

3 Piece Ordering System: Complete Fixture consists of Decorative Element, Trim-Kit, and Frame-In Kit. Each sold separately.

Example: D4A03 + C4T4VWCL + C420T4E1

Aperture	Decorative Element Catalog No.	Trim- Kit	Frame-In Kit	Lamping	Dimensions		
					A	B	C
4"	D4A03	C4T4HWCL C4T4VWCL C4T4VNCL C4T4VMCL	C420T4E1, C420T4E2 C439T4E1, C439T4E2	(1) 20W T4 (1) 39W T4	5 1/8"	6 1/4"	2"
6"	D6A03	C6T6VWCL C6T6VNCL C6T6VMCL	C639T6E1, C639T6E2,	(1) 39W T6	6 5/8"	7 3/4"	2 1/8"

Features

- Decorative element:** Angled hand blown triplex glass carefully proportioned to each aperture size. Glass is gently and evenly illuminated for clean brightness recognition.
- Die cast finish ring:** Aluminum die cast finish ring with crisp 90 degree edges conceals all fasteners for a clean finished appearance.
- Die cast construction ring:** Internal die cast construction ring is mechanically attached to frame in kit and is concealed by finish ring.
- Mounting frame fasteners:** Four #8-32 screws and 4 knurled die-cast thumb screws secure construction ring to frame in kit.
- Reflector:** Flangeless trim required. Specified separately. Use specular clear (cl) finish for best performance and aesthetics.
- Frame-in kit:** Specified separately. See trim specification sheet for additional details.

Mechanical

Die cast construction ring securely fastened to four mounting frame studs and 4 (3/8" dia.) aluminum knobs. Decorative Element and finish ring quarter turn twist and lock into die cast construction ring.

Labels

U.L. (Damp Location)

Job Information	Type:
Job Name:	
Cat. No.:	
Notes:	