

Decorative, Vetro, 4" & 6" Metal Halide

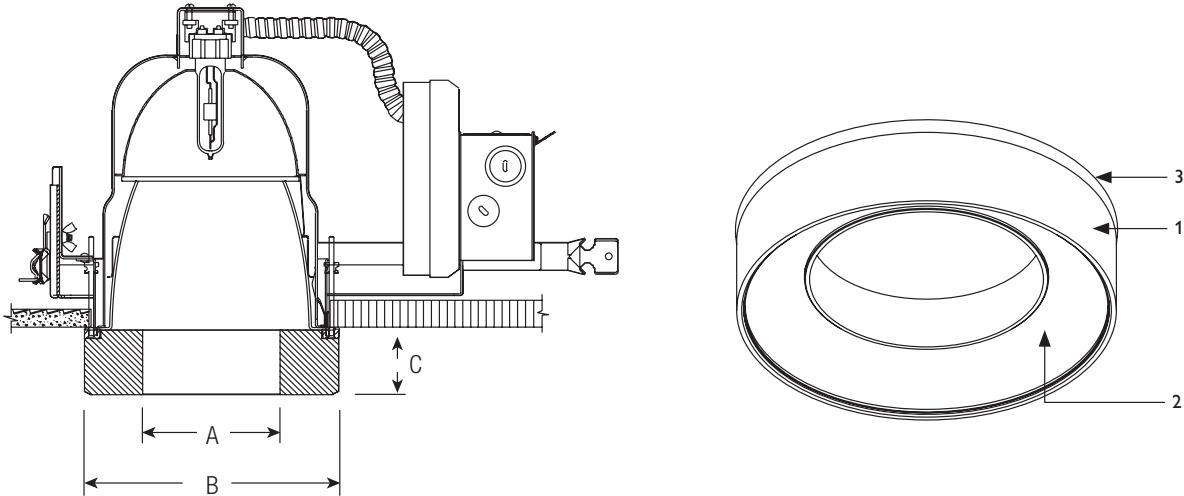

3 Piece Ordering System: Complete Fixture consists of Decorative Element, Trim-Kit, and Frame-In Kit. Each sold separately.

Example: D4A02 + C4T4VWCL + C420T4E1

Aperture	Decorative Element Catalog No.	Trim- Kit	Frame-In Kit	Lamping	Dimensions		
					A	B	C
4"	D4A02	C4T4HWCL C4T4VWCL C4T4VNCL C4T4VMCL	C420T4E1, C420T4E2 C439T4E1, C439T4E2	(1) 20W T4 (1) 39W T4	3 1/2"	6"	1 3/4"
6"	D6A02	C6T6VWCL C6T6VNCL C6T6VMCL	C639T6E1, C639T6E2,	(1) 39W T6	4"	7 1/2"	1 7/8"

Features

- Decorative element:** Solid high temp, UV resistant composite with open aperture. Interior diameter is frosted. polished exterior.
- Aluminum insert:** Satin aluminum ring is mechanically inserted in composite to create drama and intrigue in the element.
- Die cast construction ring:** Exterior edge of construction ring is visible, satin aluminum finish matches diameter of decorative element for a flangeless appearance.
- Fastener cover:** Stamped aluminum cover ring provided on top of decorative element to cover construction ring fasteners.
- Mounting frame fasteners:** Four #8-32 screws and 4 knurled die-cast thumb screws secure construction ring to frame in kit.
- Reflector:** Flangeless trim required. Specified separately. Use specular clear (CL) finish for best performance and aesthetics
- Frame-in kit:** Specified separately. See trim specification sheet for additional details.

Mechanical

Decorative elements securely fastened to four mounting frame studs.

Labels

U.L. (Damp Location)

Job Information	Type:
Job Name:	
Cat. No.:	
Notes:	