

# D7A02

## Decorative, Vetro, 7" LED

Page 1 of 1

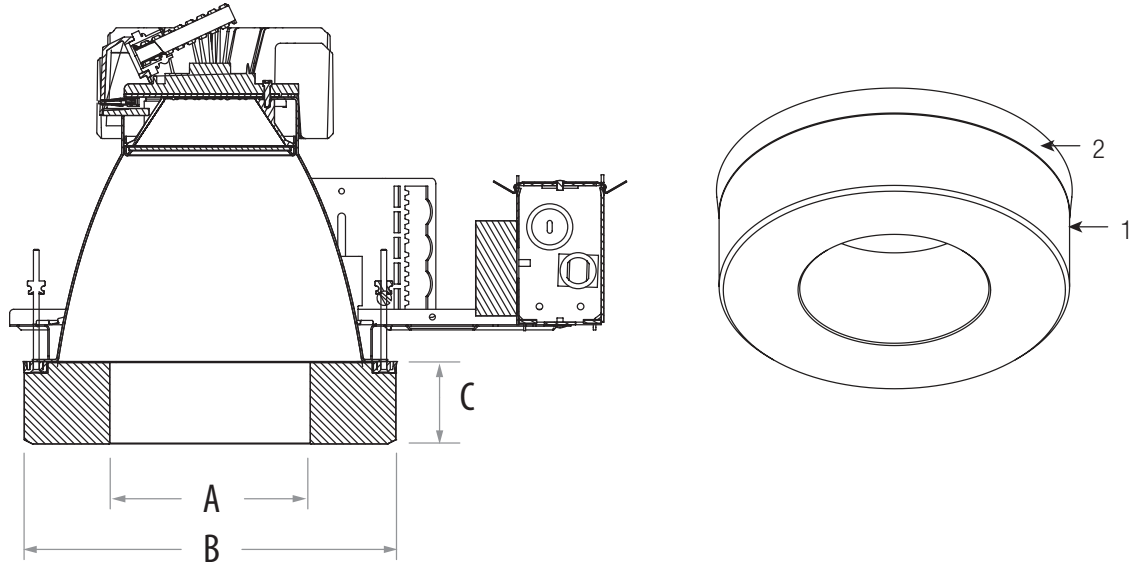

**3 Piece Ordering System:** Complete Fixture consists of Decorative Element, Calculite Light Engine, and Calculite Frame-In Kit. Each sold separately.

Aperture	Decorative Element Catalog No.	Frame-In Kit	Trim	Wattage	Dimensions		
					A	B	C
7"	D7A02	C7L1520 Series	C7L15 Series	27W	4 7/8"	9"	2"
			C7L20 Series	39W			

### Features

- Decorative element:** Solid high temp, UV resistant composite with open aperture. Interior diameter is frosted. Polished exterior.
- Die cast construction ring:** Exterior edge of construction ring is visible, satin aluminum finish matches diameter of decorative element for a flangeless appearance.
- Fastener cover:** Stamped aluminum cover ring provided on top of decorative element to cover construction ring fasteners.
- Mounting frame fasteners:** Four #8-32 screws and 4 knurled die-cast thumb screws secure construction ring to frame in kit.
- Reflector:** Flangeless trim required. Specified separately. Use specular clear (CL) finish for best performance and aesthetics
- Frame-In Kit:** Specified separately. See trim specification sheet for additional details.

### Mechanical

Decorative elements securely fastened to four mounting frame studs.

### Labels

U.L. (Damp Location)

Job Information	Type:
Job Name:	
Cat. No.:	
Notes:	

**PHILIPS**  
**LIGHTOLIER**