

D6A02

Decorative, Vetro, 6" LED

Page 1 of 1

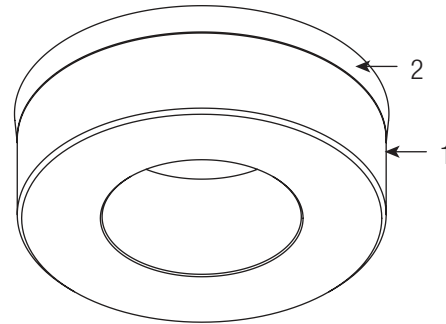
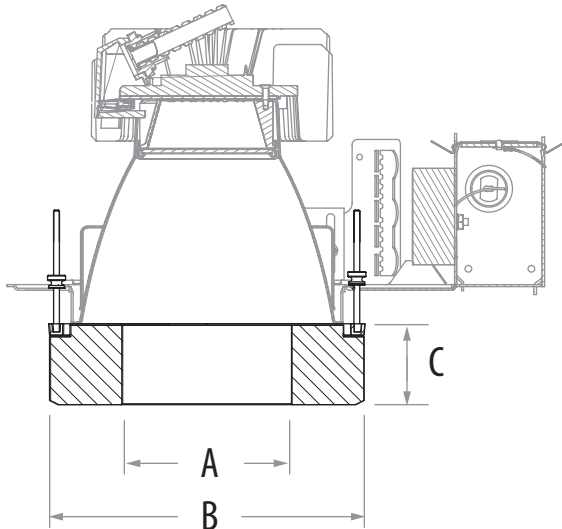

3 Piece ordering system: Complete fixture consists of decorative element, calculte light engine, and calculte frame-in kit. Each sold separately.

Aperture	Decorative element catalog no.	Flangeless trim	New construction frame-in kit	Wattage	Dimensions		
					A	B	C
6"	D6A02	C6L1520 Series	C6L15N Series	27W	4"	7 1/2"	1 7/8"
			C6L20N Series	39W			

Features

- Decorative element:** Solid high temp, UV resistant composite with open aperture. Interior diameter is frosted. Polished exterior.
- Die cast construction ring:** Exterior edge of construction ring is visible, satin aluminum finish matches diameter of decorative element for a flangeless appearance.
- Fastener cover:** Stamped aluminum cover ring provided on top of decorative element to cover construction ring fasteners.
- Mounting frame fasteners:** Four #8-32 screws and 4 knurled die-cast thumb screws secure construction ring to frame in kit.
- Reflector:** Flangeless trim required. Specified separately. Use specular clear (CL) finish for best performance and aesthetics
- Frame-in kit:** Specified separately. See trim specification sheet for additional details.

Mechanical

Decorative elements securely fastened to four mounting frame studs.

Labels

U.L. (Damp Location)

Job Information	Type:
Job Name:	
Cat. No.:	
Notes:	

PHILIPS
LIGHTOLIER