

D6A01

Decorative, Vetro, 6" LED

Page 1 of 1

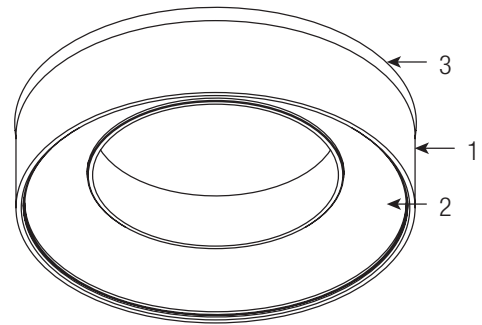
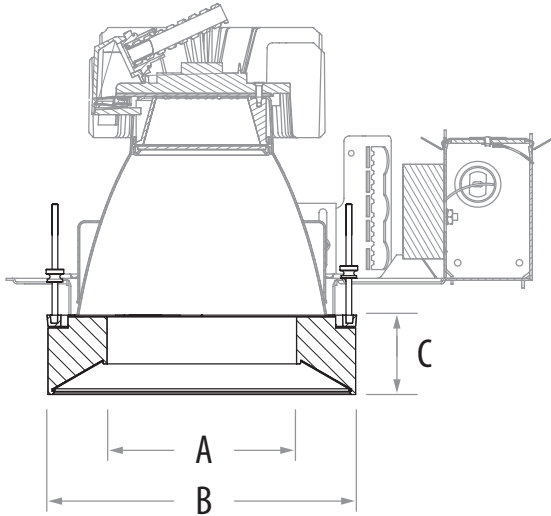

3 Piece Ordering System: Complete Fixture consists of Decorative Element, Calculite Light Engine, and Calculite Frame-In Kit. Each sold separately

Aperture	Decorative Element Catalog No.	New construction frame-in kit and flangeless trim	Wattage	Dimensions		
				A	B	C
6"	D6A01	C6L15 Series	27W	4 5/8"	7 1/2"	1 7/8"
		C6L20 Series	39W			

Features

- Decorative element:** Solid high temp, UV resistant composite with open aperture. Interior diameter is frosted. Polished exterior.
- Aluminum insert:** Satin Aluminum ring is mechanically inserted in composite to create drama and intrigue in the element.
- Die cast construction ring:** Exterior edge of construction ring is visible, satin aluminum finish matches diameter of decorative element for a flangeless appearance.
- Fastener cover:** Stamped aluminum cover ring provided on top of decorative element to cover construction ring fasteners.
- Mounting frame fasteners:** Four #8-32 screws and 4 knurled die-cast thumb screws secure construction ring to frame in kit.
- Reflector:** Flangeless trim required. Specified separately. Use specular clear (CL) finish for best performance and aesthetics
- Frame-in kit:** Specified separately. See trim specification sheet for additional details.

Mechanical

Decorative elements securely fastened to four mounting frame studs.

Labels

U.L. (Wet Location)

Job Information	Type:
Job Name:	
Cat. No.:	
Notes:	

PHILIPS
LIGHTOLIER