

# D4A13

## Architectural Decorative, Vetro, 4" LED

Page 1 of 1

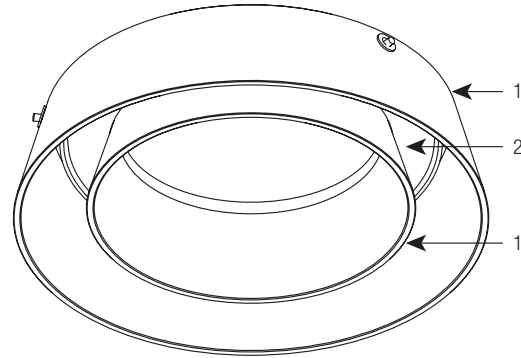
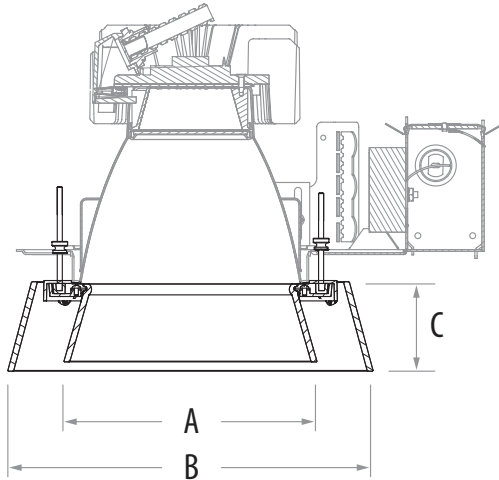

**3 Piece Ordering System:** Complete Fixture consists of Decorative Element, Calculite Light Engine, and Calculite Frame-In Kit. Each sold separately.

Aperture	Decorative Element Catalog No.	Frame-In Kit and Trim	Wattage	Dimensions		
				A	B	C
4"	D4A13	C4L05 Series	10W	5 1/8"	8 1/2"	2 1/4"
		C4L10 Series	20W			

### Features

- 1. Decorative Element:** Inner: angled hand blown triplex glass carefully proportioned to each aperture size. Glass is gently and evenly illuminated for clean brightness recognition. Outer: angled hand blown clear glass.
- 2. Die Cast Finish Ring:** Aluminum Die Cast finish ring with crisp 90 degree edges conceals all fasteners for a clean finished appearance.
- 3. Die Cast Construction Ring:** Internal die cast construction ring is mechanically attached to frame in kit and is concealed by finish ring.
- 4. Mounting Frame Fasteners:** Four #8-32 screws and 4 knurled die-cast thumb screws secure construction ring to frame in kit.
- 5. Reflector:** FLANGELESS TRIM REQUIRED. Specified separately. Use Specular Clear (CL) finish for best performance and aesthetics.
- 6. Frame-In Kit:** Specified separately. See Trim Kit Specification Sheet for additional details.

### Mechanical

Die cast construction ring securely fastened to four #8-32 screws and 4 knurled die-cast thumb screws. Decorative Element quarter turn twist and lock into die cast construction ring.

### Labels

cULus (Wet Location)

Job Information	Type:
Job Name:	
Cat. No.:	
Notes:	

**PHILIPS**  
**LIGHTOLIER**