

Features

- Excellent for lighting Cafeterias, Small Offices, Corridors, Kitchens and Family Rooms.
- White opal acrylic diffuser attacher with opaque end caps.
- Only 4 1/8" deep
- Lightshield opens and hinges from either side.
- Complete fixture consists of a diffuser and chassis.
- Zip-clip flush mount on T-grid ceilings.
- Off-center 7/8" K.O. for flush mount to T-grid ceiling.
- Not suitable for row mounting.
- Universal Belmont Series chassis compatible with:
 - Belmont Spill Frame shielding
 - Belmont Cloud shielding
 - Belmont II shielding
- Chassis shipped separate from diffuser.
- Specify and order each item separately.



Dimensions

2' X 4'

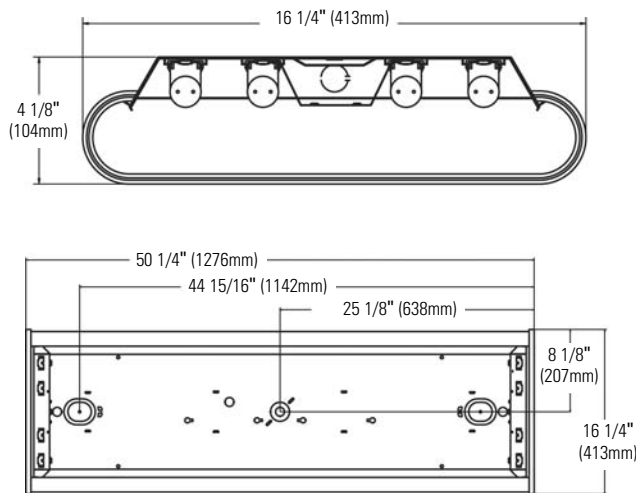

1' X 4'

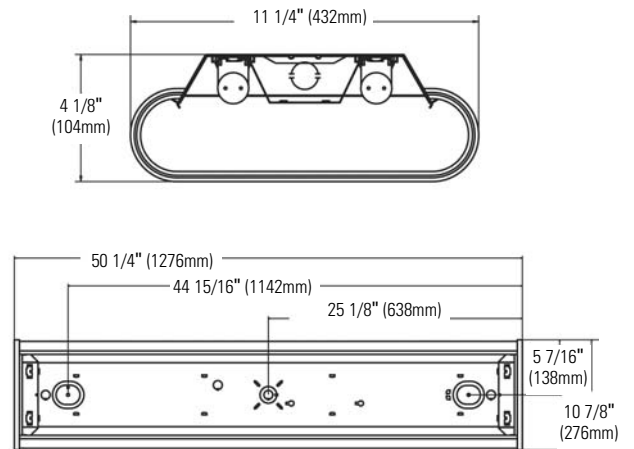

Job Information

Type:

Job Name:

Cat. No.:

Lamp(s):

Volts/Ballast:

For Factory Technical Information: (978) 657-7600 • Fax (978) 658-0595
 631 Airport Road, Fall River, MA 02720 • (508) 679-8131 • Fax (508) 674-4710
 We reserve the right to change details of design, materials and finish.
 www.lightolier.com © 2008 a Philips Group

04/08

Section 3A/Folio H10-30

Ordering Information: 2' X 4'

Chassis Code:

BE

Belmont I
Architectural
Fluorescent

2

Fixture Width:
2 = 16" wide

Body Finish:
W = White
B = Black

4

Lamp
Quantity
4 = 4 Lamp T8

32

Lamp:
(By Others)
32 = T8 32W
(Nominal 24")

UNV

Voltage:
UNV=120-277

Ballast Type:

<10THD
1 - 4 Lamp Elec. T8 **H4†**
 (32 Watt)
2 - 2 Lamp Elec. T8 **H1†**
 (32 Watt)
LOL Dimming **PS**
†Instant Start (**UNV**)

Options:

Add appropriate suffix to catalog no., ie: (GLR)
Consult factory for additional options

NOTE: Chassis and shielding are packed in separate cartons.
When ordering, enter as separate line items.

Length	Shielding	Chassis	Finish	Lamp	Ballast	10THD
4'	10328	BE2B432UNVH4	Black	4-T8	1 - 4 Lamp Elec.	H4
4'	10328	BE2W432UNVH4	White	4-T8	1 - 4 Lamp Elec.	H4
4'	10328	BE2B432UNVHI	Black	4-T8	2 - 2 Lamp Elec.	HI
4'	10328	BE2W432UNVHI	White	4-T8	2 - 2 Lamp Elec.	HI

Ordering Information: 1' X 4'

Chassis Code:

BE

Belmont I
Architectural
Fluorescent

1

Fixture Width:
1 = 10-3/4" wide

Body Finish:
W = White
B = Black

2

Lamp
Quantity
2 = 2 Lamp T8

32

Lamp:
(By Others)
32 = T8 32W
(Nominal 24")

UNV

Voltage:
UNV=120-277

Ballast Type:

<10THD
1 - 2 Lamp Elec. T8 **H1†**
 (32 Watt)
LOL Dimming **PS**
†Instant Start (**UNV**)

Options:

Add appropriate suffix to catalog no., ie: (GLR)
Consult factory for additional options

NOTE: Chassis and shielding are packed in separate cartons.
When ordering, enter as separate line items.

Length	Shielding	Chassis	Finish	Lamp	Ballast	10THD
4'	10324	BE1B232UNVHI	Black	2-T8	1 - 2 Lamp Elec.	HI
4'	10324	BE1W232UNVHI	White	2-T8	1 - 2 Lamp Elec.	HI

NOTE: Chassis and shielding shown are stock items.

Specifications

Chassis Materials - Chassis parts are cold rolled die-formed code gauge steel.

Chassis Finish: Exterior - black or white baked polyester enamel. Cavity- white baked polyester enamel minimum 86% reflectance. Phosphate undercoating.

Lens: Extruded white opal acrylic with chemically bonded opaque end caps.

Electrical: Thermally protected class "P" ballast C.B.M. approved, no PCB. If KO is within 3" of ballast, use wire suitable for at least 90°.

Labels: I.B.E.W./UL and ULc Listed.

This product may have a mercury containing lamp. Manage in accord with Disposal Laws. See: www.lamprecycle.org

Job Information

Type:

For Factory Technical Information: (978) 657-7600 • Fax (978) 658-0595
631 Airport Road, Fall River, MA 02720 • (508) 679-8131 • Fax (508) 674-4710
We reserve the right to change details of design, materials and finish.
www.lightolier.com © 2008 a Philips Group

Section 3A/Folio H10-30