

Lytecaster® Recessed Downlighting **1062LV**

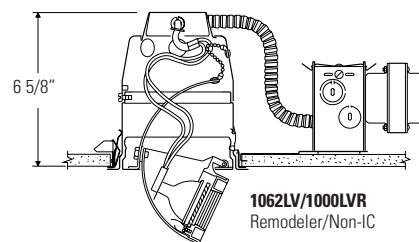
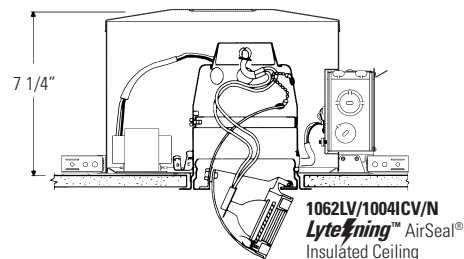
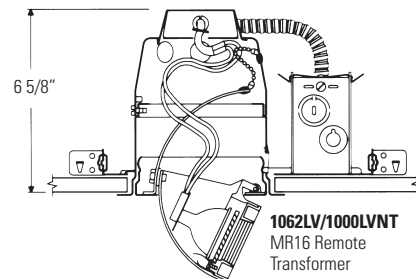
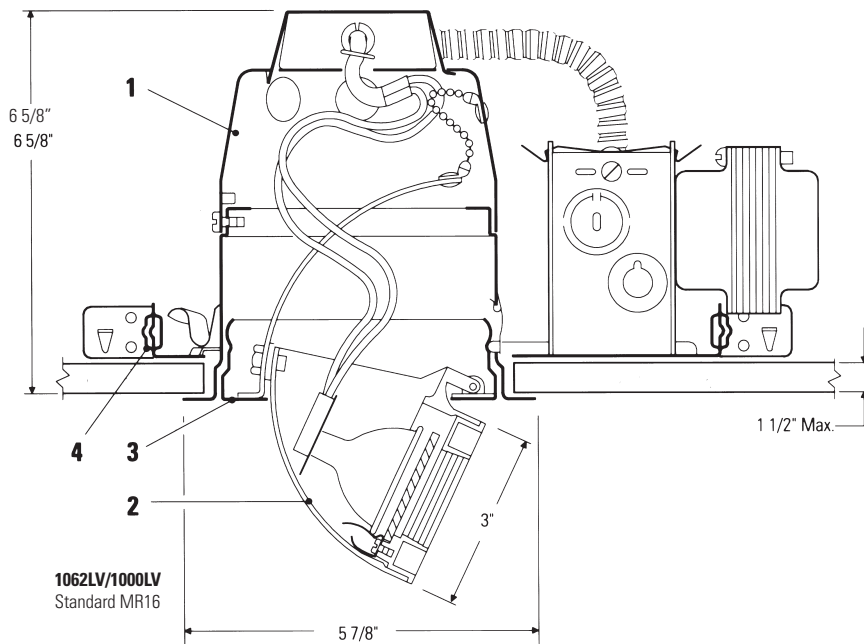

Complete Fixture consists of Reflector Trim & Frame-In Kit. Select each separately.

Reflector Trim	Frame-In Kit — See Individual Frame-In Kit Specification Sheets			
	Low Voltage			
	Frame-In Kit	Ceiling Type	Lamping	Height
1062LV Matte White	1000LV 1000LVR 1000LVE1 1000LVE2 1000LVRE1	Non-IC Non-IC Remodeler	42W - 75W MR16	6 5/8"
	1000LVNT	Non-IC Remote Trans	20W - 65W MR16	6 5/8"
	1004ICV/N	AirSeal® IC	20W - 50W MR16	7 1/4"
	1000ICV 1920LV (1002P1)	IC Conversion Kit	20W- 35W MR16	7 5/16"

Features

- Housing:** Hydroformed aluminum, .040" thick (18 ga.): matte white trim flange.
- Elbow:** Seamless; die cast aluminum with stepped conical baffle for low brightness. Matte white finish outside; matte black inside.
- Support Ring Assembly:** Provides 358° horizontal rotation and 0° to 70° vertical adjustment. Matte white finish.
- Frame-In Kit:** (1000LV standard frame shown) Other frames listed above and shown on the right. See Frame-In Kit specification sheets for more details.

Options & Accessories

- Retaining Clips:** 1955 - For Installing in Existing Ceiling.
MR16 Framing Projector: 6497 - Attaches to elbow
Extra Wide Trim Flange: 1957 - 7" Outside diameter.
MR16 Replacement Socket: 1975A

Labels

UL (Suitable for Damp Locations), I.B.E.W.

Job Information	Type:
Job Name:	
Cat. No.:	
Lamp(s):	
Notes:	

Lightolier a Genlyte company www.lightolier.com
 631 Airport Road, Fall River, MA 02720 • (508) 679-8131 • Fax (508) 674-4710
 We reserve the right to change details of design, materials and finish.
 © 2011 Genlyte Group LLC • G0811

LIGHTOLIER®



Lighting Performance Data

		Narrow																											
		20W MR16 VNSP (EZ)		20W MR16 NSP (ES)		42W MR16 VNSP (EZ)		42W MR16 NSP (EY)		42W MR16 SP (EYS)		50W MR16 NSP (EX)																	
DISTANCE																													
FOOTCANDLES (On Beam Center At 6') ▶		250		92		333		197		78		254																	
BEAM SPREAD (To 50% Max. CP)		5' x 7'		10' x 13'		7' x 9'		11.5'		20'		11' x 13'																	
MAX. CANDLEPOWER (Candelas)		9,000		3,300		12,000		7,076		2,800		9,150																	
RATED LIFE (Hours)		3,000		2,000		3,000		3,000		3,000		3,000																	
COLOR TEMPERATURE		2,925°K		2,925°K		3,000°K		3,000°K		3,000°K		3,025°K																	
0° AIMING ANGLE Illumination on Horizontal Plane																													
		D	FC	L	W	D	FC	L	W	D	FC	L	W	D	FC	L	W	D	FC	L	W	D	FC	L	W				
		7'	184	0.6'	0.9'	6'	92	1.0'	1.4'	8'	188	1.0'	1.3'	7'	144	1.4'	1.4'	4'	175	1.4'	1.4'	7'	187	1.3'	1.6'				
		10'	90	0.9'	1.2'	8'	52	1.4'	1.8'	12'	83	1.5'	1.9'	10'	71	2.0'	2.0'	6'	78	2.1'	2.1'	10'	92	1.9'	2.3'				
		13'	53	1.1'	1.6'	10'	33	1.7'	2.3'	16'	47	2.0'	2.5'	13'	42	2.6'	2.6'	8'	44	2.8'	2.8'	13'	54	2.5'	3.0'				
		16'	35	1.4'	2.0'	12'	23	2.1'	2.7'	20'	30	2.5'	3.1'	16'	38	3.2'	3.2'	10'	28	3.5'	3.5'	16'	35	3.1'	3.6'				
30° AIMING ANGLE Illumination on Horizontal Plane																													
		D	FC	L	W	D	FC	L	W	D	FC	L	W	D	FC	L	W	D	FC	L	W	D	FC	L	W	D	FC	L	W
		6'	162	0.7'	0.8'	4'	134	0.9'	1.1'	7'	159	1.1'	1.3'	6'	128	1.6'	1.4'	3'	202	1.4'	1.2'	6'	165	1.5'	1.6'				
		9'	72	1.0'	1.3'	6'	60	1.4'	1.6'	10'	77	1.6'	1.8'	9'	57	2.4'	2.1'	5'	73	2.4'	2.0'	9'	73	2.3'	2.4'				
		12'	41	1.4'	1.7'	8'	33	1.9'	2.1'	13'	46	2.1'	2.4'	12'	32	3.2'	2.8'	7'	37	3.3'	2.9'	12'	41	3.1'	3.2'				
		15'	26	1.7'	2.1'	10'	21	2.3'	2.6'	16'	30	2.6'	2.9'	15'	20	4.0'	3.5'	9'	22	4.3'	3.7'	15'	26	3.9'	3.9'				
30° AIMING ANGLE Illumination on Vertical Plane																													
		D	FC	L	W	D	FC	L	W	D	FC	L	W	D	FC	L	W	D	FC	L	W	D	FC	L	W	D	FC	L	W
		2'	281	0.7'	0.5'	2'	103	1.4'	0.9'	3'	167	1.5'	0.9'	2'	221	1.7'	0.8'	1'	350	1.6'	0.7'	2'	286	1.6'	0.9'				
		3'	125	1.1'	0.7'	3'	46	2.1'	1.4'	4'	94	2.0'	1.3'	3'	98	2.5'	1.2'	2'	88	3.1'	1.4'	3'	127	2.4'	1.4'				
		4'	70	1.4'	1.0'	4'	26	2.9'	1.8'	5'	60	2.5'	1.6'	4'	55	3.3'	1.6'	3'	39	4.7'	2.1'	4'	71	3.2'	1.8'				
		5'	45	1.8'	1.2'	5'	17	3.6'	2.3'	6'	41	3.0'	1.9'	5'	35	4.2'	2.0'	4'	22	6.2'	2.8'	5'	46	4.0'	2.3'				
45° AIMING ANGLE Illumination on Vertical or (Horizontal) Plane																													
		D	FC	L	W	D	FC	L	W	D	FC	L	W	D	FC	L	W	D	FC	L	W	D	FC	L	W	D	FC	L	W
		4'	199	0.7'	0.7'	3'	130	1.1'	1.0'	5'	170	1.2'	1.1'	4'	156	1.6'	1.1'	3'	110	2.2'	1.5'	4'	202	1.6'	1.3'				
		6'	88	1.0'	1.0'	5'	47	1.8'	1.6'	7'	87	1.7'	1.6'	6'	69	2.4'	1.7'	4'	62	2.9'	2.0'	6'	90	3.2'	1.9'				
		8'	50	1.4'	1.4'	7'	24	2.5'	2.3'	9'	52	2.2'	2.0'	8'	39	3.3'	2.3'	5'	40	3.6'	2.5'	8'	51	3.1'	2.6'				
		10'	32	1.7'	1.7'	9'	14	3.2'	2.9'	11'	35	2.7'	2.4'	10'	25	4.1'	2.8'	6'	27	4.4'	3.0'	10'	32	3.9'	3.2'				

		Medium				Wide															
		50W MR16 NFL (EX)		20W MR16 FL (BAB)		42W MR16 FL (EYP)		50W MR16 FL (EXN)													
DISTANCE																					
FOOTCANDLES (On Beam Center At 6') ▶		83		13		28		42													
BEAM SPREAD (To 50% Max. CP)		22' x 27'		36' x 37'		36'		37' x 39'													
MAX. CANDLEPOWER (Candelas)		3,000		460		991		1,500													
RATED LIFE (Hours)		3,000		2,000		3,000		3,000													
COLOR TEMPERATURE		3,025°K		2,950°K		3,050°K		3,050°K													
0° AIMING ANGLE Illumination on Horizontal Plane																					
		D	FC	L	W	D	FC	L	W	D	FC	L	W	D	FC	L	W	D	FC	L	W
		6'	83	2.3'	2.9'	2'	115	1.3'	1.3'	3'	110	1.9'	1.9'	4'	94	2.7'	2.8'				
		8'	47	3.1'	3.8'	4'	29	2.6'	2.7'	5'	40	3.2'	3.2'	6'	42	4.0'	4.2'				
		10'	30	3.9'	4.8'	6'	13	3.9'	4.0'	7'	20	4.5'	4.5'	8'	23	5.4'	5.7'				
		12'	21	4.7'	5.8'	8'	7	5.2'	5.3'	9'	12	5.8'	5.8'	10'	15	6.7'	7.1'				
30° AIMING ANGLE Illumination on Horizontal Plane																					
		D	FC	L	W	D	FC	L	W	D	FC	L	W	D	FC	L	W	D	FC	L	W
		4'	122	2.1'	2.2'	2'	75	1.8'	2.5'	3'	72	2.7'	2.3'	3'	108	2.8'	2.5'				
		6'	54	3.1'	3.3'	4'	19	3.6'	3.1'	5'	26	4.5'	3.8'	5'	39	4.6'	4.1'				
		8'	30	4.2'	4.4'	6'	8	5.4'	4.6'	7'	13	6.3'	5.3'	7'	20	6.5'	5.7'				
		10'	19	5.2'	5.5'	8'	5	7.2'	6.1'	9'	8	8.1'	6.8'	9'	12	8.3'	7.4'				
30° AIMING ANGLE Illumination on Vertical Plane																					
		D	FC	L	W	D	FC	L	W	D	FC	L	W	D	FC	L	W	D	FC	L	W
		2'	94	3.5'	1.9'	1'	58	3.8'	1.3'	1'	124	3.8'	1.3'	1'	188	4.0'	1.4'				
		3'	42	5.3'	2.9'	2'	14	7.6'	2.7'	2'	31	7.6'	2.6'	2'	47	8.1'	2.8'				
		4'	23	7.0'	3.8'	3'	6	11.4'	4.0'	3'	14	11.4'	3.9'	3'	21	12.1'	4.2'				
		5'	15	8.8'	4.8'	4'	4	15.2'	5.3'	4'	8	15.2'	5.2'	4'	12	16.1'	5.7'				
45° AIMING ANGLE Illumination on Vertical or (Horizontal) Plane																					
		D	FC	L	W	D	FC	L	W	D	FC	L	W	D	FC	L	W	D	FC	L	W
		3'	118	2.4'	2.0'	2'	41	2.9'	1.9'	2'	88	2.9'	1.8'	2'	133	3.0'	2.0'				
		5'	42	4.0'	3.4'	3'	18	4.4'	2.8'	3'	39	4.4'	2.8'	3'	59	4.5'	3.0'				
		7'	22	5.7'	4.8'	4'	10	5.8'	3.8'	4'	22	5.8'	3.7'	4'	33	6.0'	4.0'				
		9'	13	7.3'	6.1'	5'	7	7.3'	4.7'	5'	14	7.3'	4.6'	5'	21	7.5'	5.0'				

Beam Center Location	
Distance D (ft.)	1 2 3 4 5 6 7 8 9 10
Distance C (ft.)	1.7 3.5 5.2 6.9 8.7 10.4 12.1 13.8 15.6 17.3
<small>This chart locates the distance (C) to the center of the light beam for various distances (D) when the lamp is aimed 30° from vertical, the preferred aiming angle for lighting pictures on a wall</small>	

Data are based on bare lamp photometrics. Dashed lines in beam spreads indicate narrow axes of oval shaped beams. FC is initial footcandles at center of beam. L and W are to the point that the candlepower drops 50% of maximum

To convert lighting data for a lower wattage incandescent lamp of the same type, multiply the footcandle (or candlepower) values by the ratio of the lumens of the two lamps. The coefficients of utilization remain the same.

Job Information Type:

Lightolier a Genlyte company www.lightolier.com
 631 Airport Road, Fall River, MA 02720 • (508) 679-8131 • Fax (508) 674-4710
 We reserve the right to change details of design, materials and finish.
 © 2011 Genlyte Group LLC • G0811